

ENFRIADORES AGUA-ACEITE SERIE 82

SERIE	MODELO	A	B	C	E	Conex. Aceite Ø1	Conex. Agua Ø2	Caudal Aceite	Capacidad de Enfriamiento		Caudal Agua	Peso
		mm				BSPT	BSPT	Litros/min.	Kcal/hora	kW	Litros/min.	kg
82	170	170	235	82	90	1/2"	1/2"	10 – 15	1500 – 3000	1,7 – 3,5	20	2,7
	300	300	365	82	220	1/2"	1/2"	15 – 35	3000 – 7000	3,5 – 8,1	25	5,7
	380	380	445	82	300	3/4"	1/2"	35 – 50	7000 – 11000	8,1 – 12,8	35	7,1
	480	480	545	82	400	3/4"	1/2"	50 – 70	11000 – 15000	12,8 – 17,4	50	7,5

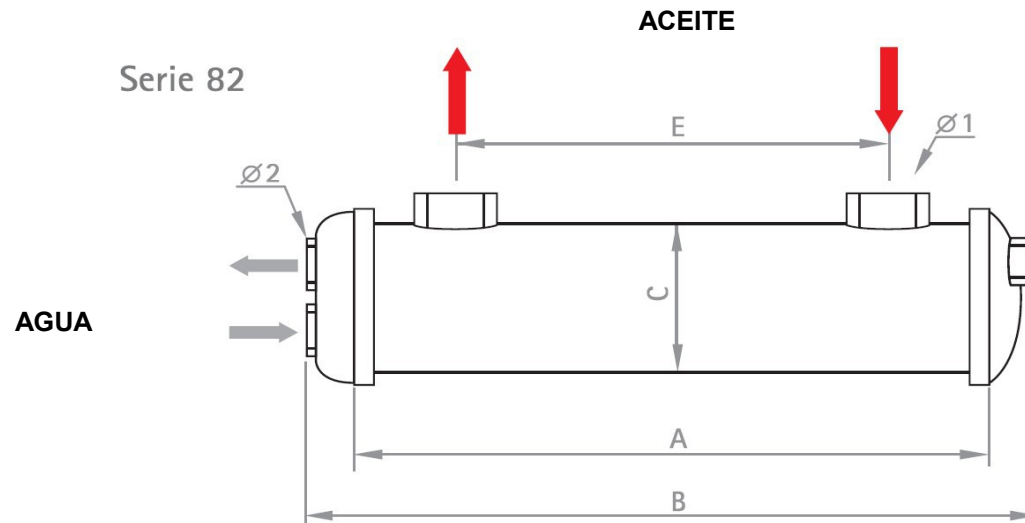

SERIE	MODELO	A	B	C	E	Conex. Aceite Ø1	Conex. Agua Ø2	Caudal Aceite	Capacidad de Enfriamiento		Caudal Agua	Peso
		mm				BSPT	BSPT	Litros/min.	Kcal/hora	kW	Litros/min.	kg
114ST	380	380	460	114	255	1"	3/4"	70 – 100	15000 – 20000	17,4 – 23,3	60	18
	500	500	580	114	370	1 1/4"	3/4"	100 – 120	20000 – 23000	23,3 – 26,7	70	23
114	500	500	615	114	340	1 1/2"	1"	80 – 100	18000 – 22000	20,9 – 25,6	60	23
	750	750	865	114	590	1 1/2"	1"	100 – 120	22000 – 27000	25,6 – 31,4	70	29
	1050	1050	1165	114	890	1 1/2"	1"	120 – 140	27000 – 31000	31,4 – 36,0	80	36
	1250	1250	1365	114	1090	2"	1"	140 – 160	31000 – 35000	36,0 – 40,7	90	46
140	500	500	615	141	340	1 1/2"	1"	80 – 100	21000 – 27000	24,4 – 31,4	60	32
	750	750	865	141	590	1 1/2"	1"	100 – 120	27000 – 36000	31,4 – 41,9	80	42
	1050	1050	1165	141	890	1 1/2"	1"	120 – 140	36000 – 45000	41,9 – 52,3	100	52
	1250	1250	1365	141	1090	2"	1"	140 – 160	45000 – 52000	52,3 – 60,5	120	58

ACEITE

Serie 114 - 140 - 150 - 200

